



ASME PVP[®] 2025

Pressure Vessels & Piping[®] Conference

Conference: July 20–25, 2025

Exhibition: July 21-23, 2025

Hotel Bonaventure
Montreal, Quebec, Canada



PVP2025-151692

SEALING PERFORMANCE OF VARIOUS PASS BAR RIB GASKET STYLES

Robert Taylor – 3S Superior Sealing Services LLC



Sealing Performance of Various Pass Bar Rib Gasket Styles

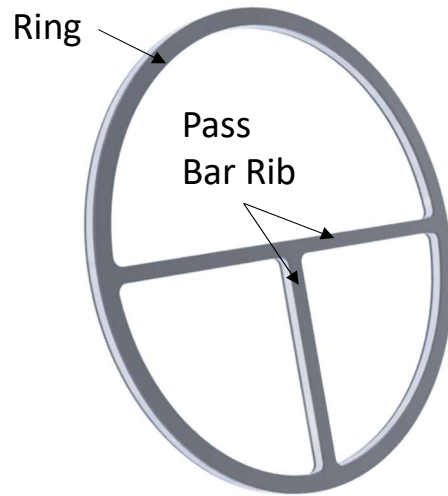

Heat Exchanger gaskets are a critical part of ensuring the unit operates safely and as efficiently as possible.

It is noticeable when the ring part of the gasket is not creating a seal but is the pass bar rib part of the gasket performing the same as the ring?

This presentation evaluates the sealing performance of different ring / pass bar rib combinations to better understand: is the heat exchanger performing to the maximum efficiency across the pass bar rib section.

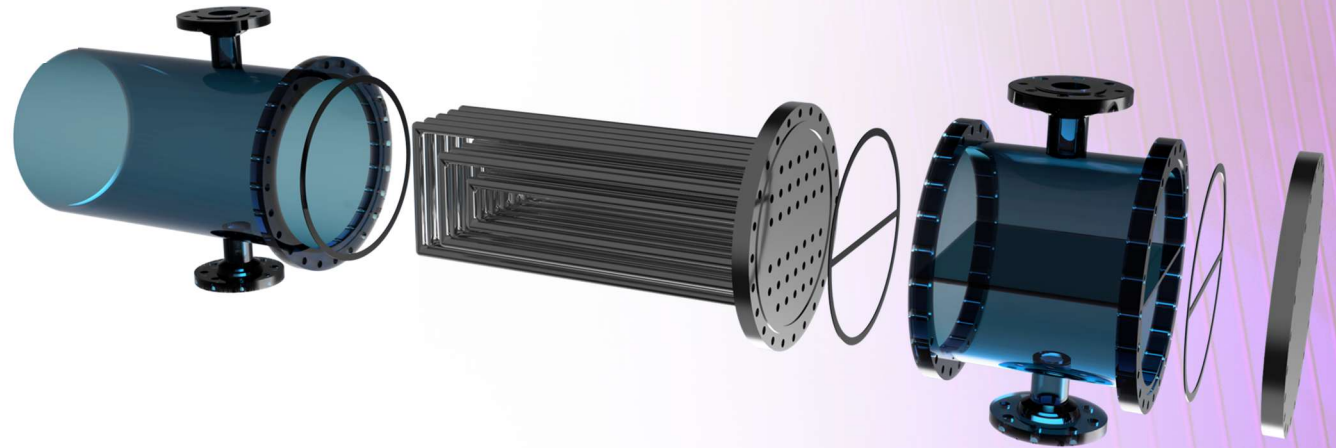

Sealing Performance of Various Pass Bar Rib Gasket Styles

Test Machine - Setup

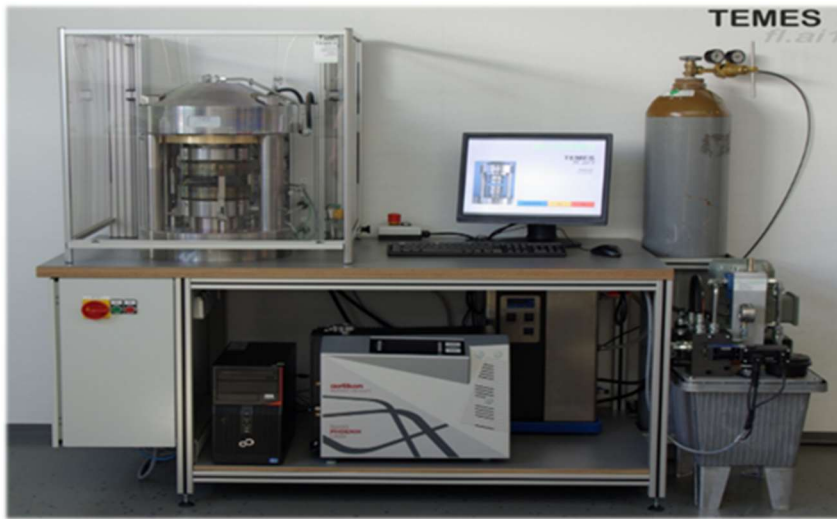

All testing was conducted by Amtec North America on a "Temes fl.ai.1".

A specially designed 3S top platen was machined so the leakage rate of the pass bar rib section of the gasket could be measured.

The average results will be presented in – Leakage rate and pressure drop.

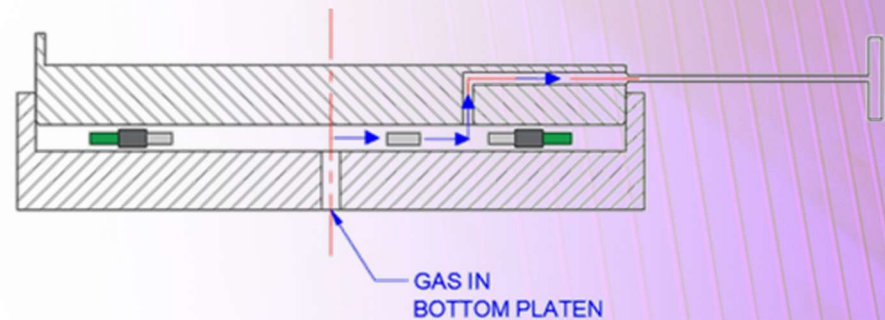

Sealing Performance of Various Pass Bar Rib Gasket Styles

Test Procedure

Step	Gasket Stress – MPa (psi)
1	69 (10,000)
2	97 (14,069)
3	124 (17,985)
4	152 (22,046)
5	179 (25,962)
6	69 (10,000)

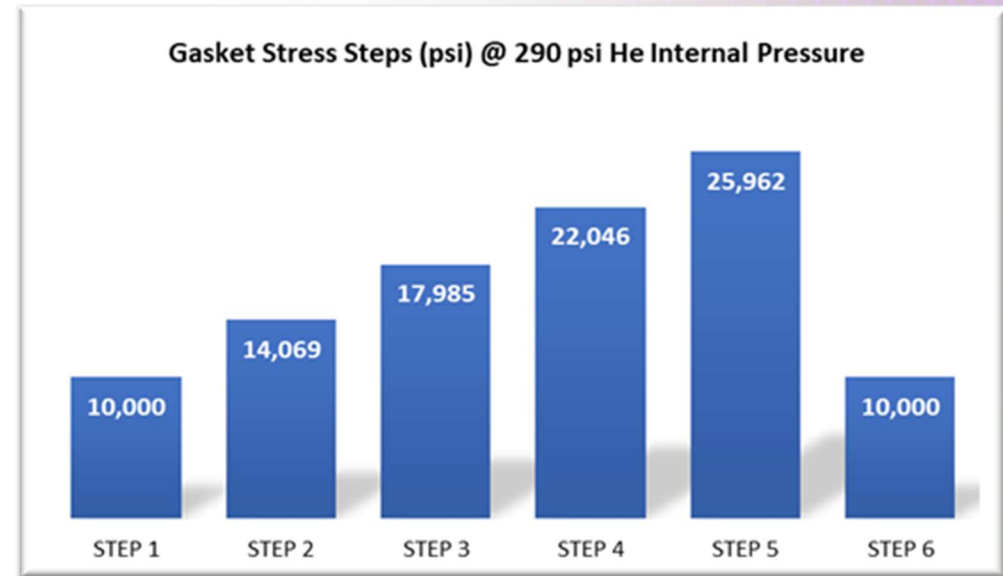

An internal pressure of 20 bar (290 psi) was the target point at each gasket stress value.
The test media for this project was helium gas.

Sealing Performance of Various Pass Bar Rib Gasket Styles

Gasket Styles

From our experience of manufacturing heat exchanger gaskets, the following products have been included in the project. All gasket have a combination of 316L SS and Flexible Graphite

Ring – Pass Bar Rib



DJ - DJ



SWG Inner & Outer Rings - Kamm



SWG Outer Rings - DJ

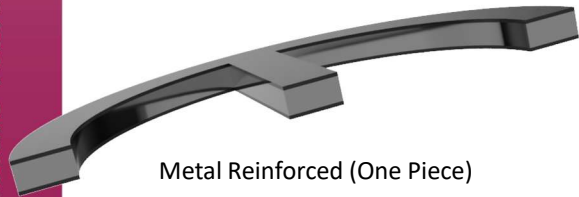

Metal Reinforced (One Piece)

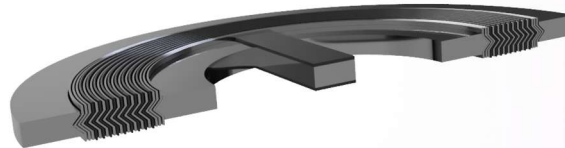

SWG Inner & Outer Rings - MRG

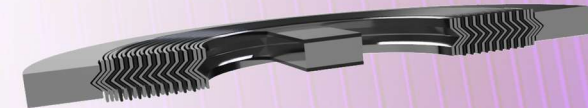

SWG Outer Rings - MRG

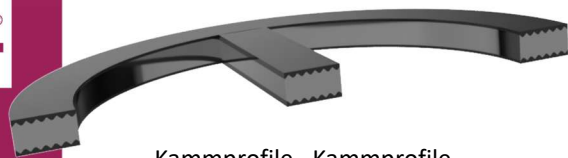

Kammprofile - Kammprofile



SWG Inner & Outer Rings - DJ

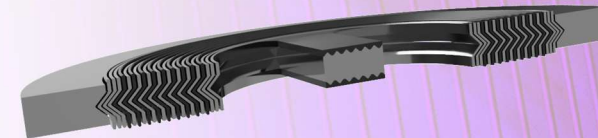

SWG Outer Rings - Kamm



Kamm Ring



MRG Ring



DJ Ring



SWG OR Ring (GS)



SWG IR & OR Ring (GSI)

Sealing Performance of Various Pass Bar Rib Gasket Styles

To enable us to compare the pass bar rib sealing properties against the ring gaskets we performed separate tests on the below.

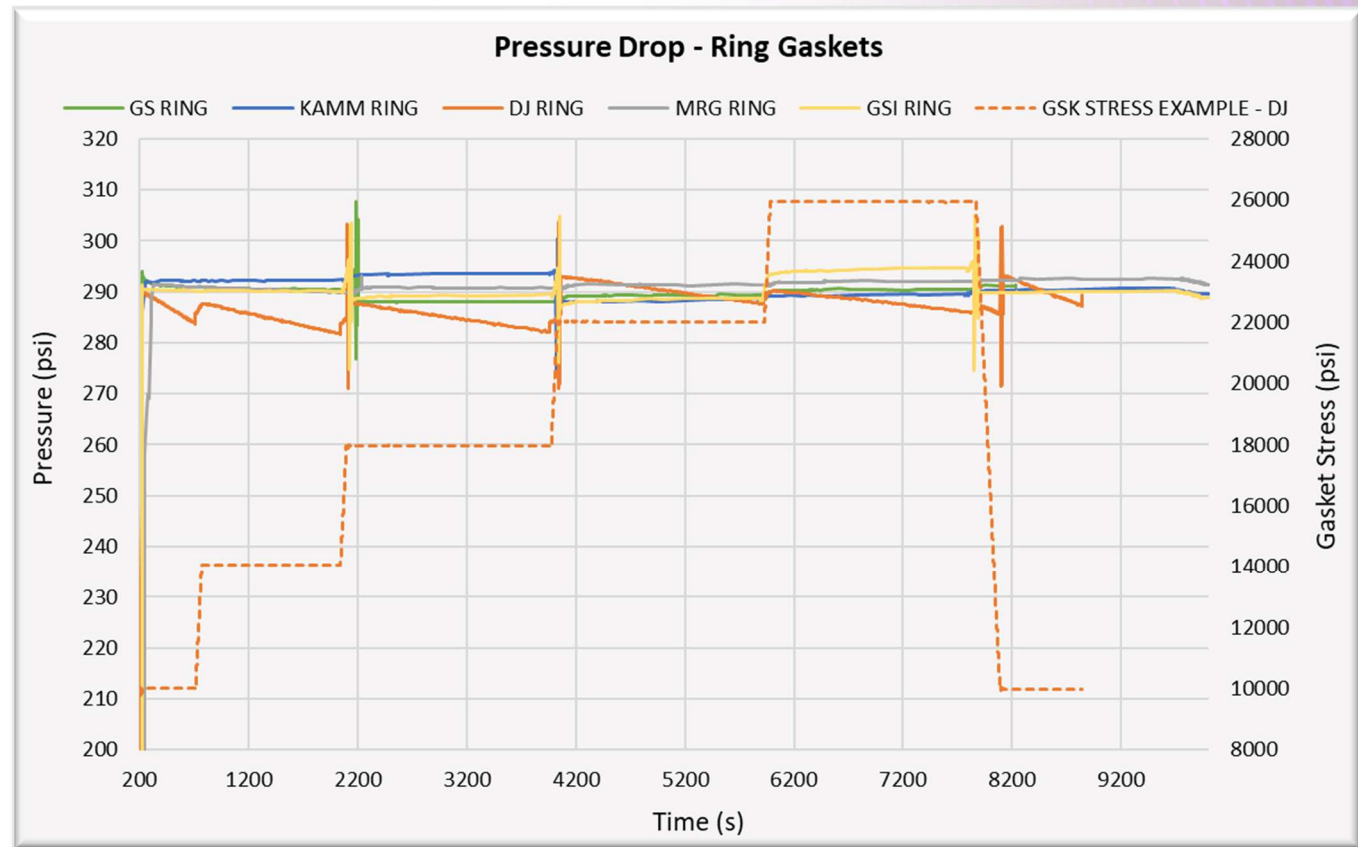

Sealing Performance of Various Pass Bar Rib Gasket Styles



Test Results - Rings

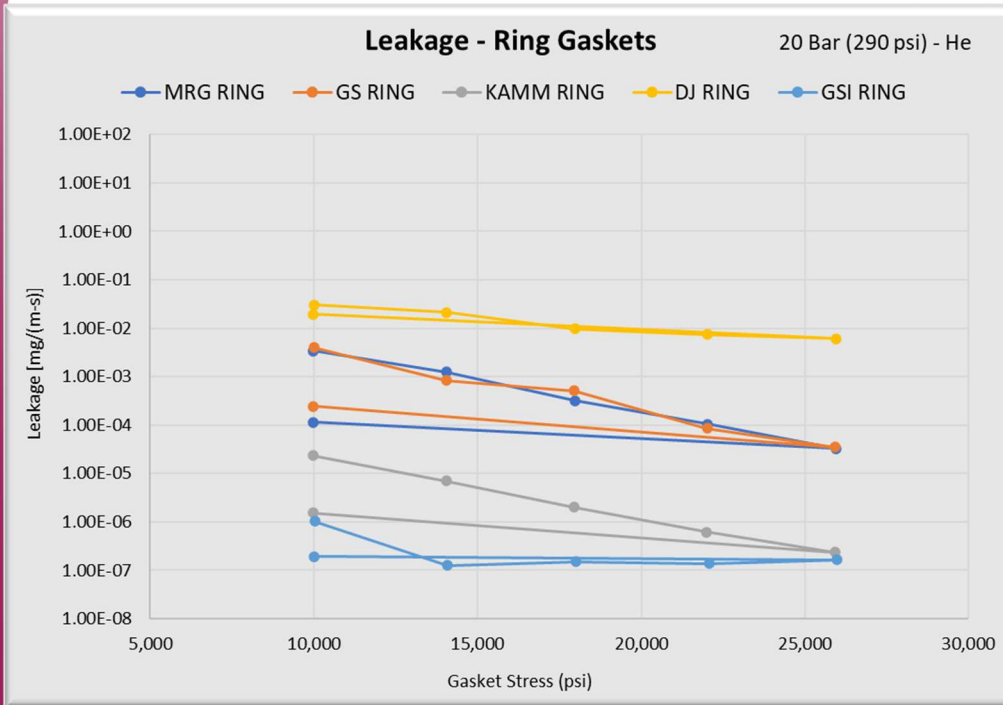

Gasket Stress MPa (psi)	KAMM	DJ	MRG	GS	GSI
69 (10,000)	0.0000234	0.03019	0.00342	0.00392	0.000001
97 (14,069)	0.0000070	0.02130	0.00123	0.00082	0.00000013
124 (17,985)	0.0000020	0.00965	0.00032	0.00051	0.00000015
152 (22,046)	0.0000006	0.00746	0.000105	0.00008	0.00000014
179 (25,962)	0.0000002	0.00611	0.000033	0.00003	0.00000016
69 (10,000)	0.0000015	0.01952	0.000115	0.00024	0.00000019

Sealing Performance of Various Pass Bar Rib Gasket Styles



Pass Bar Rib Thickness vs Ring Thickness

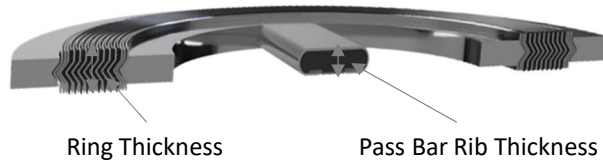

Gasket Ring – Pass Bar Rib	Thickness – Gasket Ring	Thickness – Pass Bar Rib
KAMM – KAMM	0.158" (4.01mm)	0.158" (4.01mm)
DJ – DJ	0.125" (3.18mm)	0.125" (3.18mm)
MRG – MRG	0.160" (4.06mm)	0.160" (4.06mm)
GS – KAMM	0.194" (4.93mm)	0.158" (4.01mm)
GS- FLAT BAR	0.195" (4.95mm)	0.156" (3.96mm)
GS – DJ	0.196" (4.98mm)	0.154" (3.91mm)
GS – DJ THK	0.196" (4.98mm)	0.185" (4.71mm)
GSI – DJ	0.195" (4.95mm)	0.151" (3.84mm)
GSI – FLAT BAR	0.196" (4.98mm)	0.157" (3.99mm)
GSI – KAMM	0.196" (4.98mm)	0.158" (4.01mm)

The typical heat exchanger gaskets have different pass bar rib styles to the ring gasket; with this you will have different thicknesses of the two sealing elements. The table to the left shows average thicknesses of the ring and pass bar ribs tested.

With having different gasket styles in the heat exchanger gasket, you also have different compression rates.



Sealing Performance of Various Pass Bar Rib Gasket Styles

Test Results – SWG – Outer Ring

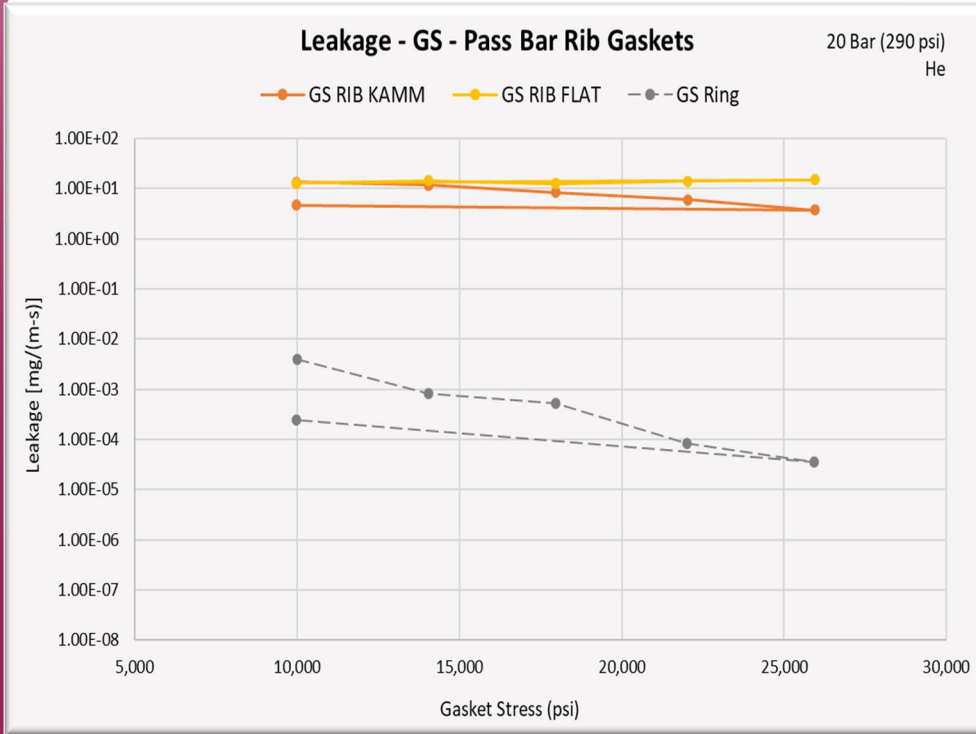

Gasket Stress MPa (psi)	GS - KAMM	GS – FLAT BAR	GS – DJ	GS Ring
69 (10,000)	13.336	12.914	LEAK RATE TOO HIGH TO RECORD	0.00392
97 (14,069)	11.825	14.357		0.00082
124 (17,985)	8.447	12.483		0.00051
152 (22,046)	5.934	14.131		0.00008
179 (25,962)	3.710	14.841		0.00003
69 (10,000)	4.645	12.915		0.00024

Leakage results for GS Style gaskets with various pass bar rib gaskets.

Please note leakage results for GS – DJ gasket is not shown in this information because the leakage rate was too high for the TEMES fl.ai1 to record.



Sealing Performance of Various Pass Bar Rib Gasket Styles

Test Results – SWG – Outer Ring



GS – DJ
SWG Outer Rings - DJ



GS – FLAT BAR
SWG Outer Rings - MRG



GS – KAMM
SWG Outer Rings - Kamm

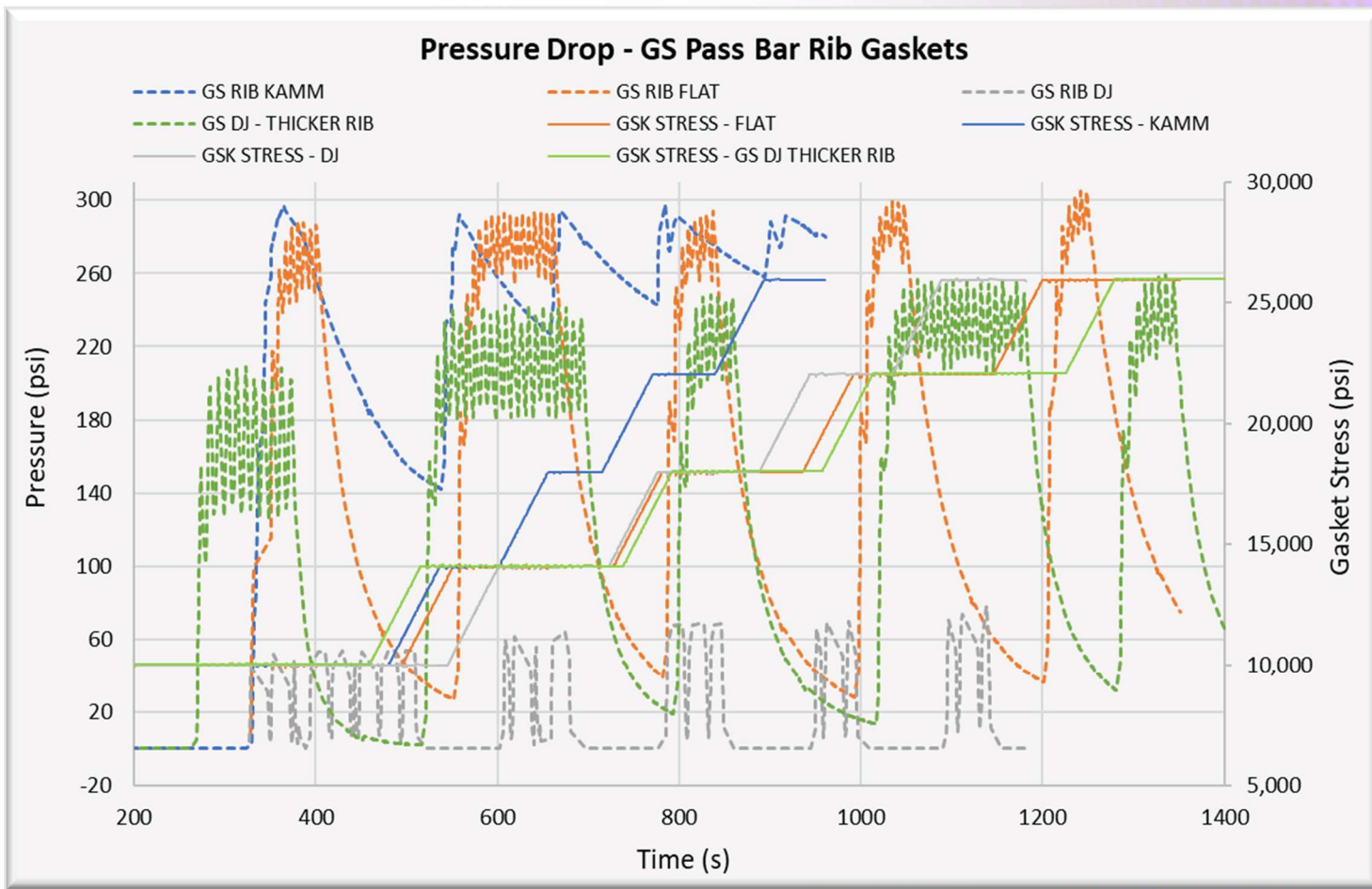



GSI – KAMM RIB
SWG Inner & Outer Rings - Kamm

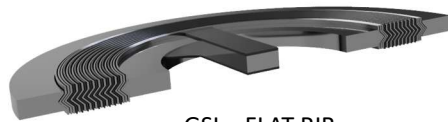

GSI – FLAT RIB
SWG Inner & Outer Rings - MRG



GSI DJ RIB
SWG Inner & Outer Rings - DJ

Due to the design of this gasket none of the rib styles – DJ Rib, Flat Bar Rib and Kamm Rib were able to create a seal due to high leakage. The TEMES fl.ai1 test machine could not read these values. The data in the graph shows the pressure drop results. The leakage rate on the GSI – DJ was that high the internal pressure didn't reach 10 psi.

Sealing Performance of Various Pass Bar Rib Gasket Styles Test Results – SWG – Inner & Outer Ring

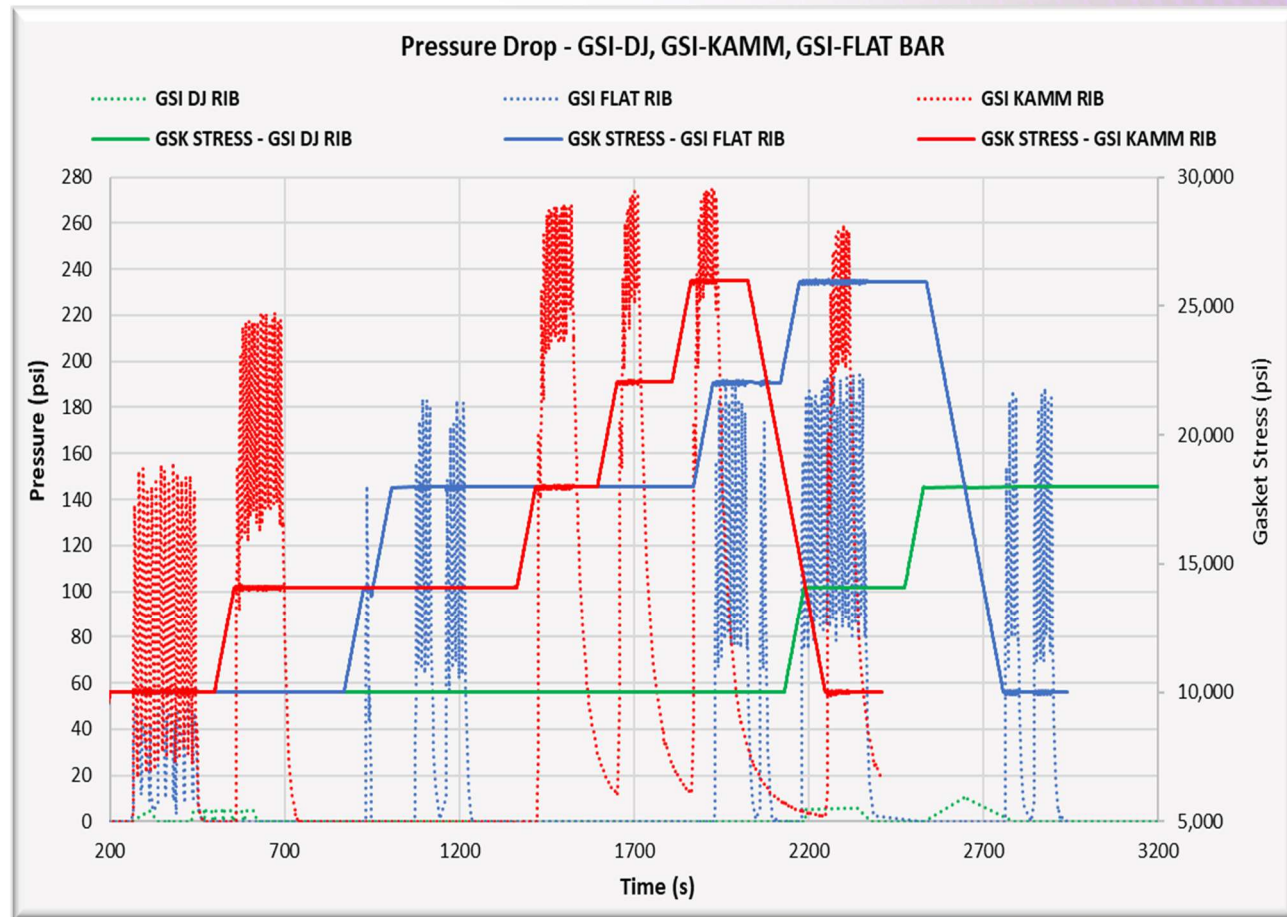



Sealing Performance of Various Pass Bar Rib Gasket Styles

Test Results – SWG – Inner & Outer Ring

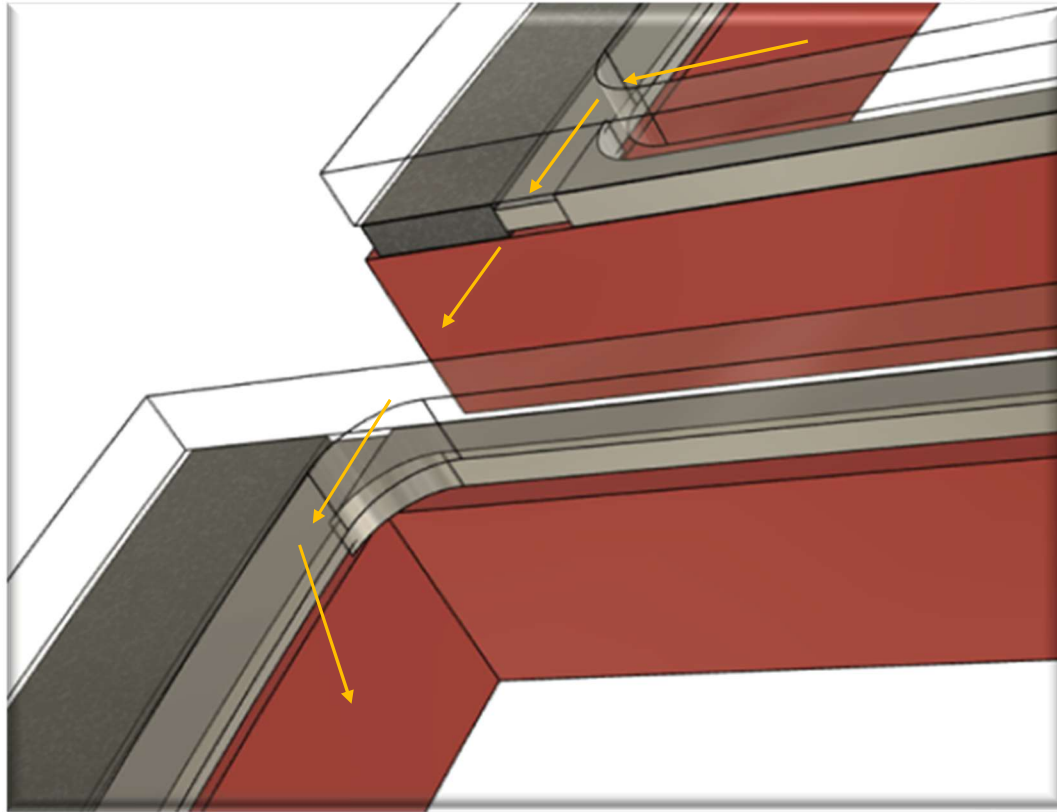

GSI style gaskets with any pass bar rib design show high leak rates, this may be due to the gaskets rigidity with the inclusion of the inner ring.

Another reason for higher leakage rates on the GSI-DJ gasket compared to other gaskets is there will always be a leak path across the inner ring, this is illustrated to the left.

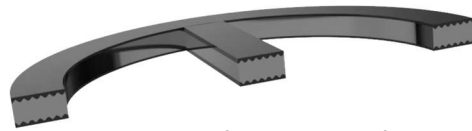

Kammprofile - Kammprofile

Gasket Stress MPa (psi)	KAMM - Ring	KAMM – Pass Bar Rib
69 (10,000)	0.0000234	0.153662
97 (14,069)	0.0000070	0.030497
124 (17,985)	0.0000020	0.003745
152 (22,046)	0.0000006	0.000215
179 (25,962)	0.0000002	0.000059
69 (10,000)	0.0000015	0.001988

The KAMM Ring values are lower than the KAMM Pass Bar Rib but are still within a satisfactory range for pass bar rib gaskets. The slight difference in leakage rates could be due to the distribution of gasket stress across the pass bar rib or imperfections in the joint where the pass bar rib is attached to the ring gasket.

Both sets of results show a decrease in leakage as the gasket stress increases.

Sealing Performance of Various Pass Bar Rib Gasket Styles Test Results – Kammprofile

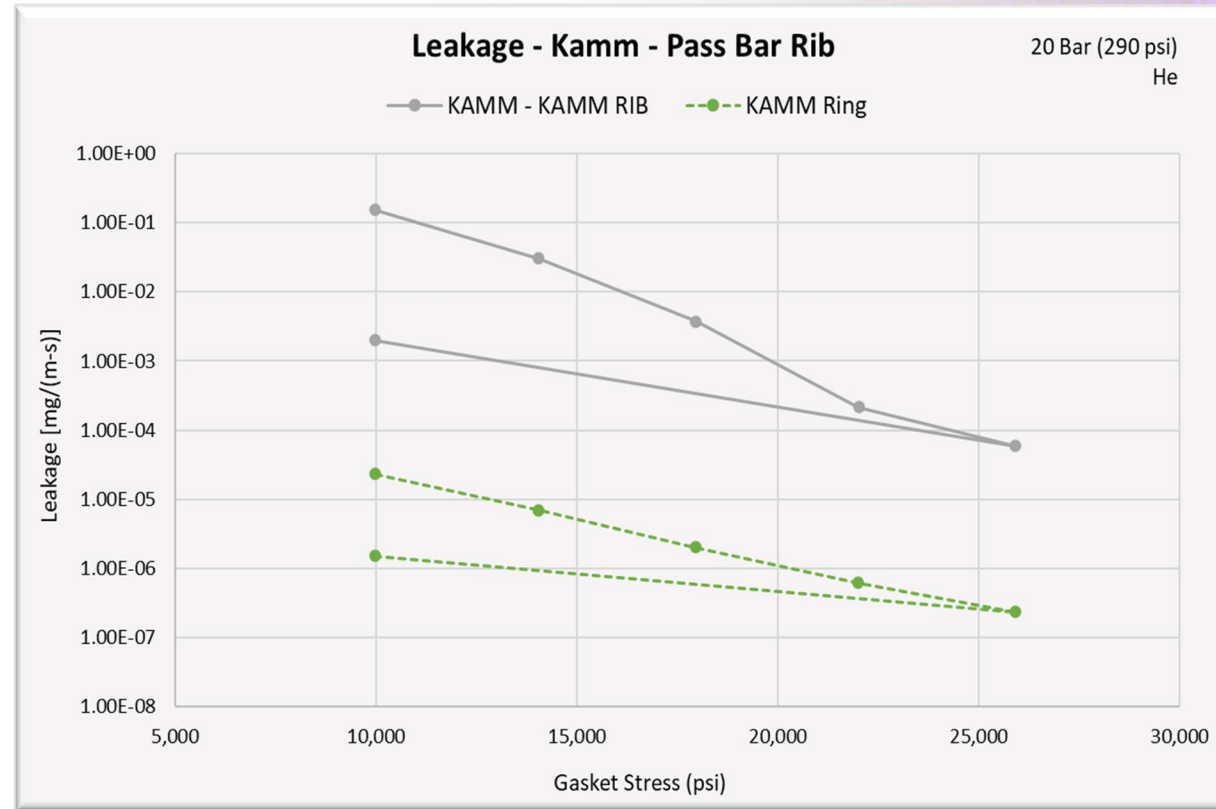

Due to the leakage rates being low on both the KAMM Ring and KAMM Pass Bar Rib the pressure drop graph didn't show any significant results, this graph will not be displayed in this section.

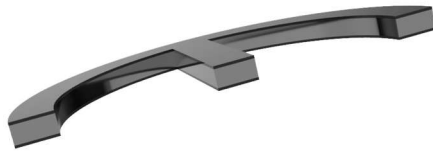

Metal Reinforced (MRG - One Piece)

Gasket Stress MPa (psi)	MRG - Ring	MRG – Pass Bar Rib
69 (10,000)	0.003425	0.010527
97 (14,069)	0.00123	0.003716
124 (17,985)	0.000321	0.000283
152 (22,046)	0.000105	0.000083
179 (25,962)	0.0000330	0.0000239
69 (10,000)	0.000115	0.0000769

Leakage results for both MRG Ring and MRG pass bar rib gaskets are the most consistent, this will be due to the one-piece construction ensuring the gasket is the same thickness for the pass bar rib gasket and no welds are present.

Sealing Performance of Various Pass Bar Rib Gasket Styles

Test Results – MRG (Metal Reinforced Gasket)

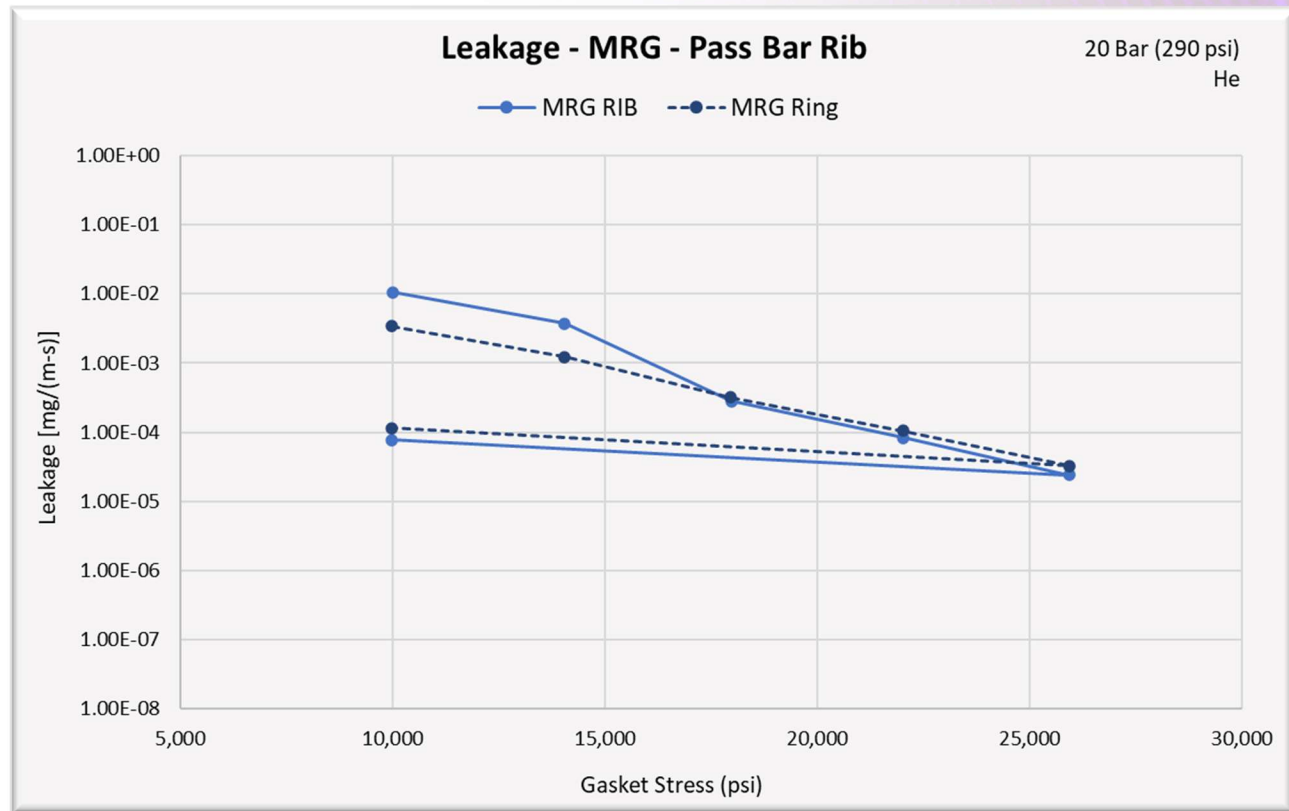



DJ - DJ

Sealing Performance of Various Pass Bar Rib Gasket Styles Test Results DJ - DJ

Gasket Stress MPa (psi)	DJ - Ring	DJ - Pass Bar Rib
69 (10,000)	0.030198	12.430
97 (14,069)	0.021309	12.122
124 (17,985)	0.009650	11.360
152 (22,046)	0.007467	10.864
179 (25,962)	0.006114	11.228
69 (10,000)	0.019527	21.668

The ring gaskets leak rate reduced as gasket stress increased but the leakage rate for the pass bar rib section showed no decrease as the gasket stress increased.

At 17,985 psi of gasket stress the ring seal is 1,177 times tighter than the pass bar rib.

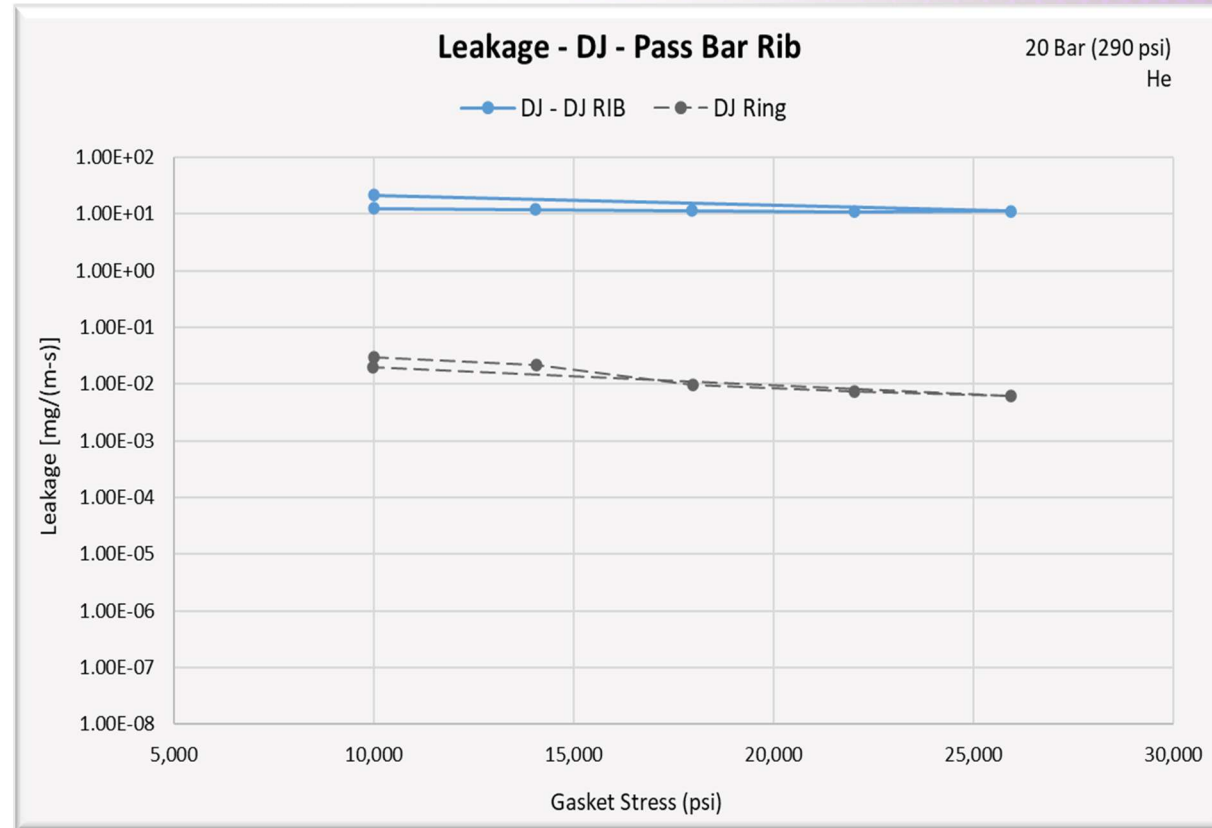



DJ - DJ

From this data (pressure drop graph) it is easy to see why the pass bar rib section of the gasket has a higher leak rate, the reduction in pressure through each gasket stress step is high.

Sealing Performance of Various Pass Bar Rib Gasket Styles Test Results DJ - DJ

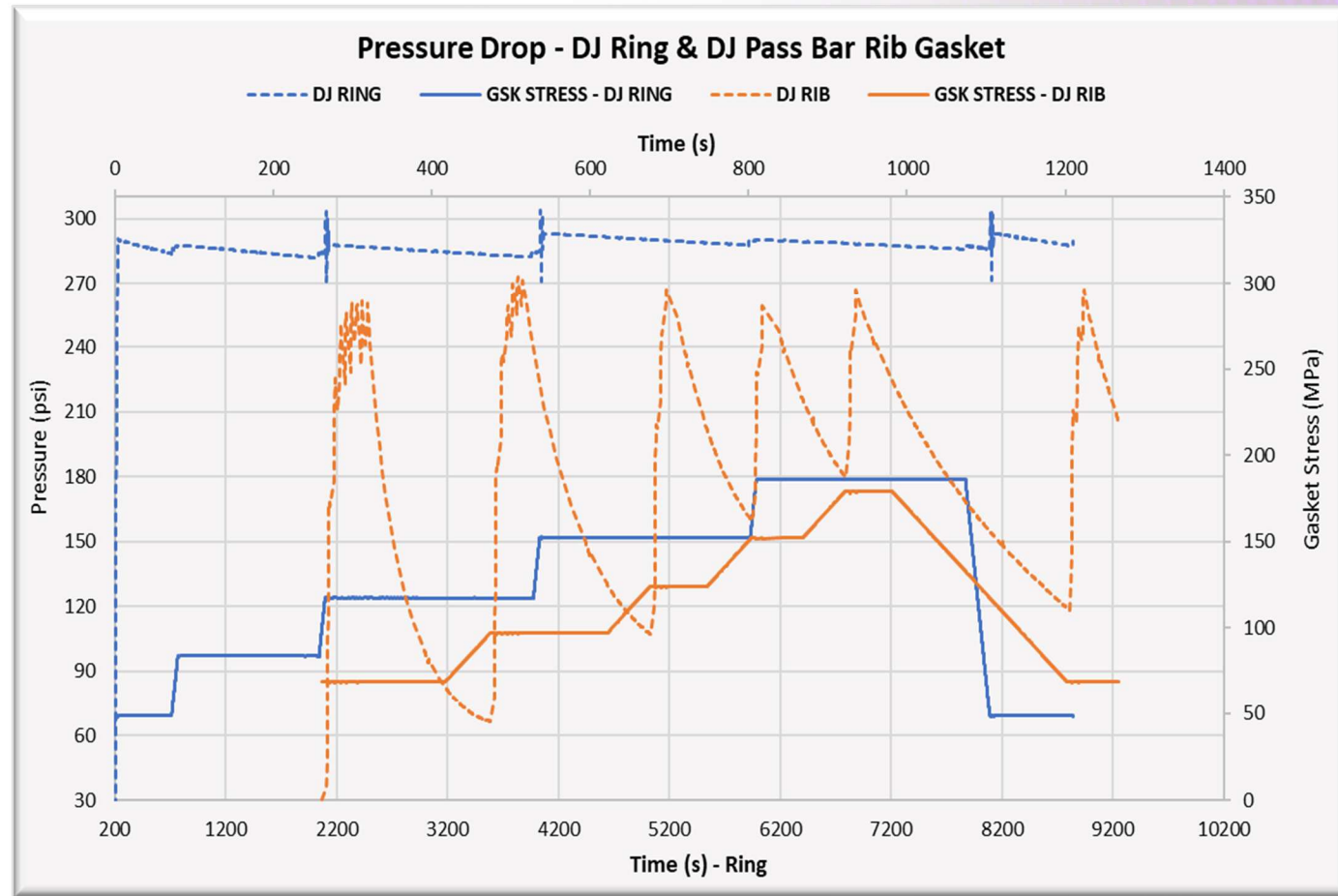



Sealing Performance of Various Pass Bar Rib Gasket Styles

Pass Bar Rib Summary

Gasket Ring – Pass Bar Rib	Thickness – Gasket Ring	Thickness – Pass Bar Rib	Gasket Stress – Pass Bar Rib Contact	Leakage Rate Recorded?
KAMM - KAMM	0.158" (4.01mm)	0.158" (4.01mm)	0	YES
DJ - DJ	0.125" (3.18mm)	0.125" (3.18mm)	0	YES
MRG - MRG	0.160" (4.06mm)	0.160" (4.06mm)	0	YES
GS - KAMM	0.194" (4.93mm)	0.158" (4.01mm)	6,663 psi (45.7 MPa)	YES
GS- FLAT BAR	0.195" (4.95mm)	0.156" (3.96mm)	6,344 psi (43.7 MPa)	YES
GS - DJ	0.196" (4.98mm)	0.154" (3.91mm)	6,088 psi (42.0 MPa)	NO
GSI-DJ THK	0.196" (4.98mm)	0.185" (4.71mm)	1,810 psi (12.0 MPa)	NO
GSI - DJ	0.195" (4.95mm)	0.151" (3.84mm)	7,770 psi (53.6 MPa)	NO
GSI – FLAT BAR	0.196" (4.98mm)	0.157" (3.99mm)	8,569 psi (59.1 MPa)	NO
GSI - KAMM	0.196" (4.98mm)	0.158" (4.01mm)	6,098 psi (42.0 MPa)	NO

Sealing Performance of Various Pass Bar Rib Gasket Styles

Pass Bar Rib Summary

Gasket Stress MPa (psi)	KAMM- KAMM	DJ-DJ	MRG-MRG	GS- KAMM	GS-FLAT BAR
69 (10,000)	0.153662	12.430	0.010527	13.336	12.914
97 (14,069)	0.030497	12.122	0.003716	11.825	14.357
124 (17,985)	0.003745	11.360	0.000283	8.447	12.483
152 (22,046)	0.000215	10.864	0.000083	5.934	14.131
179 (25,962)	0.000059	11.228	0.0000239	3.710	14.841
69 (10,000)	0.001988	21.668	0.0000769	4.645	12.915

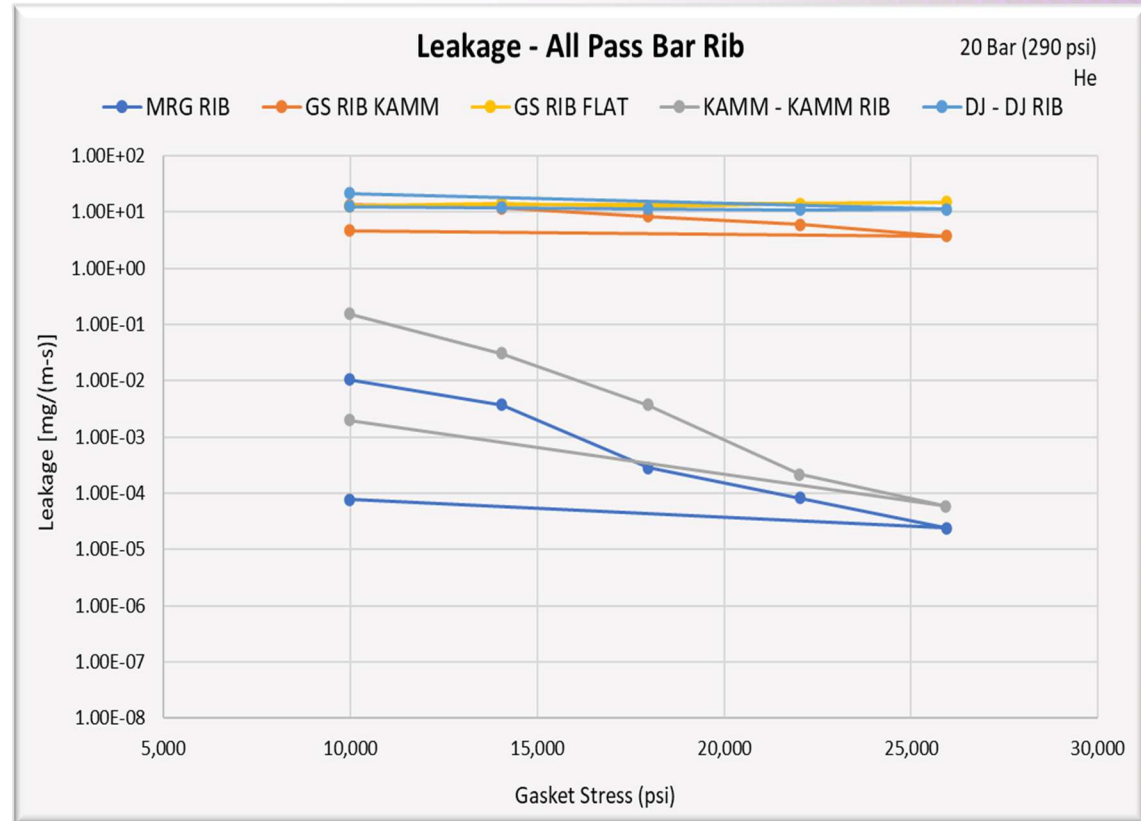

Sealing Performance of Various Pass Bar Rib Gasket Styles

Summary

- The test results from this study show a large variation of sealing performance of both ring gaskets and pass bar rib options. The different combinations also result in varying leakage rates.
- The gasket style that offers a more consistent sealing performance between the ring and pass bar rib combination in these test conditions was the one-piece construction MRG-MRG gasket.
- Using a spiral wound gasket that has an inner ring with a pass bar rib shows very high leakage rates.
- This study was done in a laboratory environment using a small molecule gas in helium as the test media, it is understood that the test media will be different in actual applications but it still highlights the wide range of sealing performances in the gasket styles tested. This variation will affect the performance and efficiency of the heat exchanger process.



Sealing Performance of Various Pass Bar Rib Gasket Styles

Tested Gaskets Examples

